



NEW JEWELRY WORK BENCH



PARTS IDENTIFICATION

(A) RIGHT SIDE - 1



(B) LEFT SIDE - 1



(C) UPPER AND LOWER CROSSBARS (IDENTICAL) - 2



(D) REAR PANEL SUPPORT BAR - 1



(E) BACK PANELS (IDENTICAL) - 2



(F) BOTTOM OF BENCH BODY - 1



(G) RIGHT SIDE PANEL OF BENCH BODY (3 TRACKS ON ONE SIDE) - 1



(H) CENTER PANEL OF BENCH BODY (3 TRACKS ON ONE SIDE, ONE TRACK ON OPPOSITE SIDE) - 1



(I) LEFT SIDE OF THE BENCH (ONLY ONE TRACK) - 1



(J) BENCH BODY TOP - 1



(K) BENCH TOP - 1



(O) DRAW BOTTOMS - 3



PARTS IDENTIFICATION

(L1) LARGE DRAWER
FRONT - 1



(L2) LARGE DRAWER
SIDES- 2



(L3) LARGE DRAWER
BACK- 1



(M1) MEDIUM DRAWER
FRONT - 1



(M2) MEDIUM DRAWER
SIDES- 2



(M3) MEDIUM DRAWER
BACK- 1



(N1) SMALL DRAWER
FRONT - 1



(N2) SMALL DRAWER
SIDES- 2



(N3) SMALL DRAWER
BACK- 1



(P) BENCH PIN HOLDER - 1



(Q) BENCH PIN - 1



(R) ARM RESTS - 2



Assembly Tools Required

1. Allen wrench (included)
2. Screwdriver straight $\frac{1}{4}$ " blade
3. Screwdriver Phillips.

HARDWARE

- 2 $\frac{1}{2}$ " BOLT - 8 PCS.
- 1 $\frac{1}{2}$ " BOLT - 19 PCS.
- 1 $\frac{1}{4}$ " BOLT - 15 PCS.
- WOOD DOWELS - 8 PCS.
- PLASTIC CAMS - 6 PCS.
- INSERT CAMS - 26 PCS.
- 2 $\frac{1}{4}$ " WOOD SCREWS - 8 PCS.
- $\frac{3}{4}$ " WOOD SCREWS - 24 PCS.
- ALLEN WRENCH - 1 PC.



1

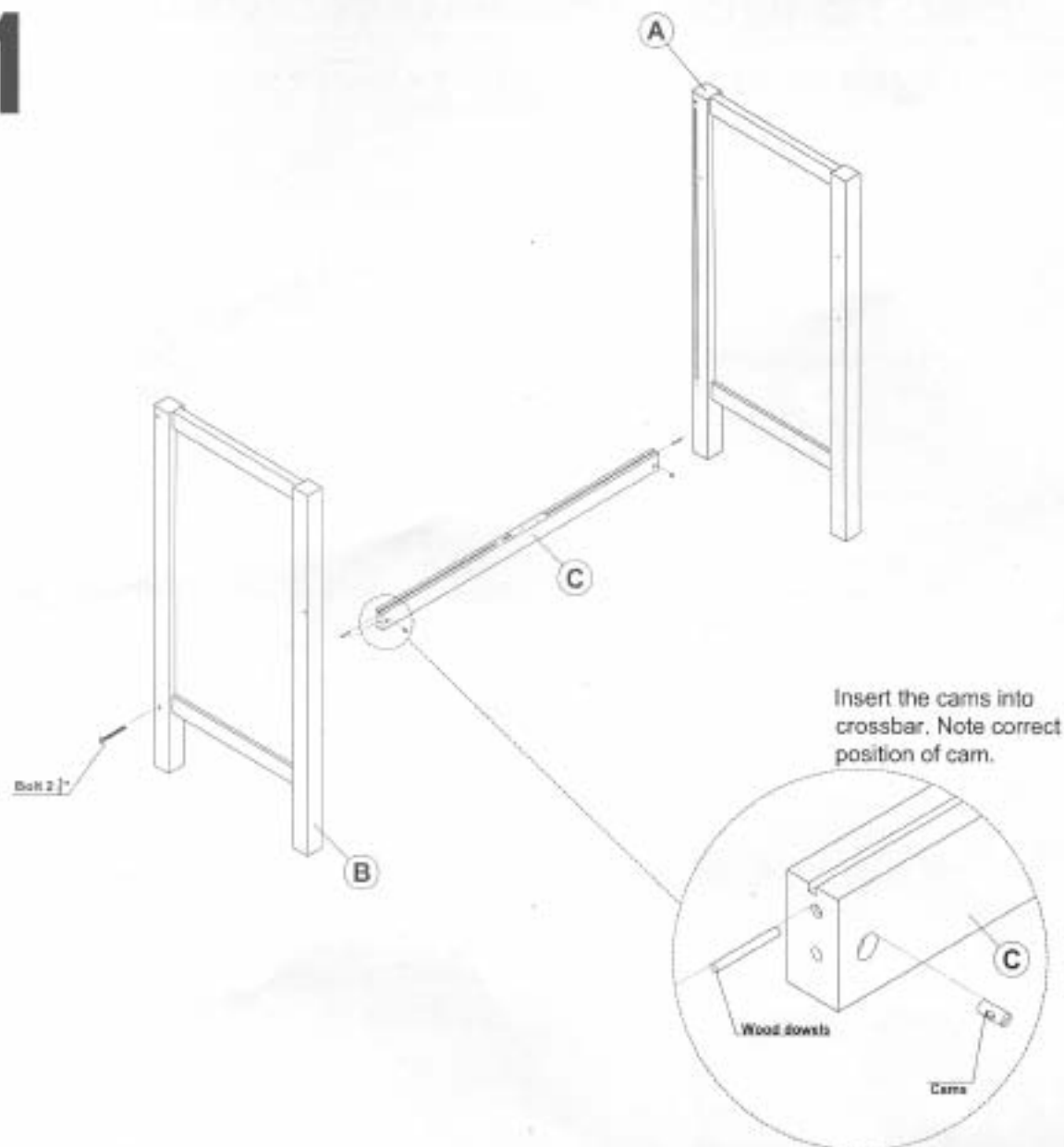

PARTS IDENTIFICATION

- A Right Side - (1)
- B Left Side - (1)
- C Upper and Lower Crossbars - (identical)

STAGE 1- Bench Frame Assembling Step 1

Attach lower cross bar (C) to sides A and B.

1. Insert two cams into crossbar. Note correct position of cam as shown in illustration.
2. Insert wood dowels into top hole of crossbar. See illustration.
3. Fasten both sides to lower cross bar using 2 1/2" bolts. Bolts screw into cams. If alignment is not correct, adjust using screwdriver to rotate the cam. Do not fully tighten.

2

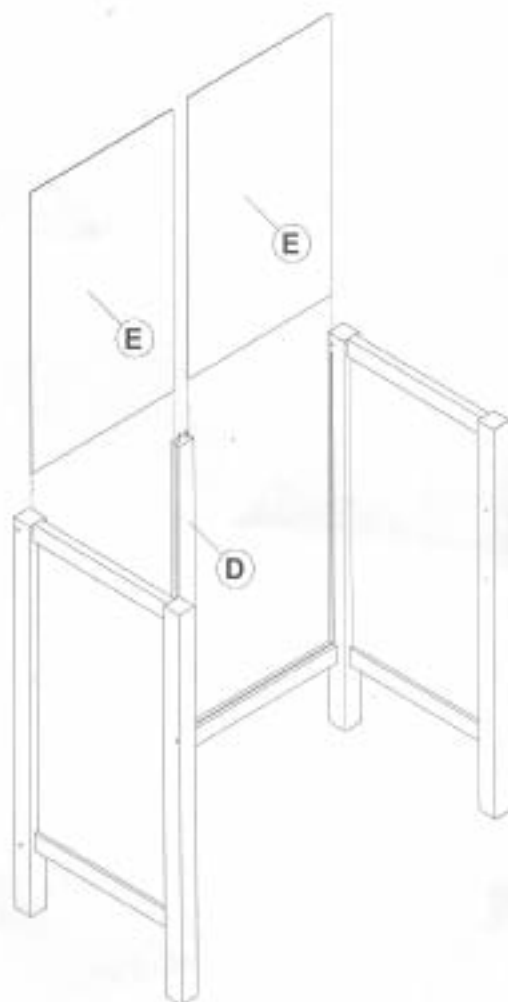

PARTS IDENTIFICATION

- A Right Side - (1)
- B Left Side - (1)
- C Upper and Lower Crossbars - (identical)
- D Rear panel support bar - (1)
- E Back panels - (2 pieces, identical)

STAGE 1- Bench Frame Assembling

Step 2

1. Insert two wood dowels into one side of the Rear Panel Support Bar (D).
2. Attach to the lower cross bar.
3. Insert back panel (E) into grooves on right side (A), lower crossbar (C), and rear support bar (D).
4. Repeat for left side.

3

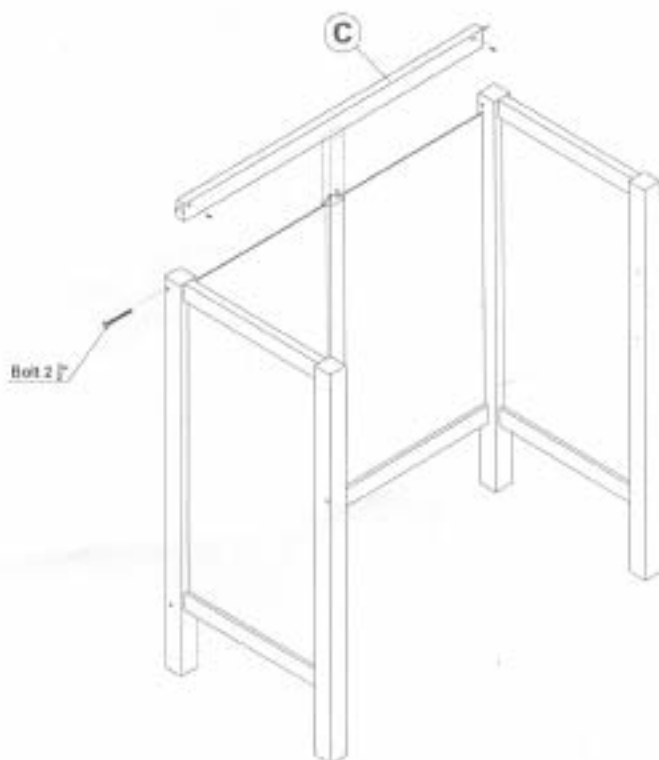

Final image of the Bench Support



PARTS IDENTIFICATION

- A Right Side - (1)
- B Left Side - (1)
- C Upper and Lower Crossbars - (Identical)
- D Rear panel support bar - (1)
- E Back panels - (2 pieces, identical)

STAGE 1- Bench Frame Assembling

Step 3

1. Position 4 dowels into holes on both sides panels (A and B) and the rear support bar (D).
2. Slightly tilt both sides. Fit both back panels into all grooves.
3. Insert cams (2) into upper cross bar.
4. Fit upper crossbar (C) over dowels on Rear Support Panel (D).
5. Position back panels (E) into all grooves.
6. Attach both sides to upper crossbar using 2 1/2" bolts. Tighten all bolts, top and bottom, tightly.

4

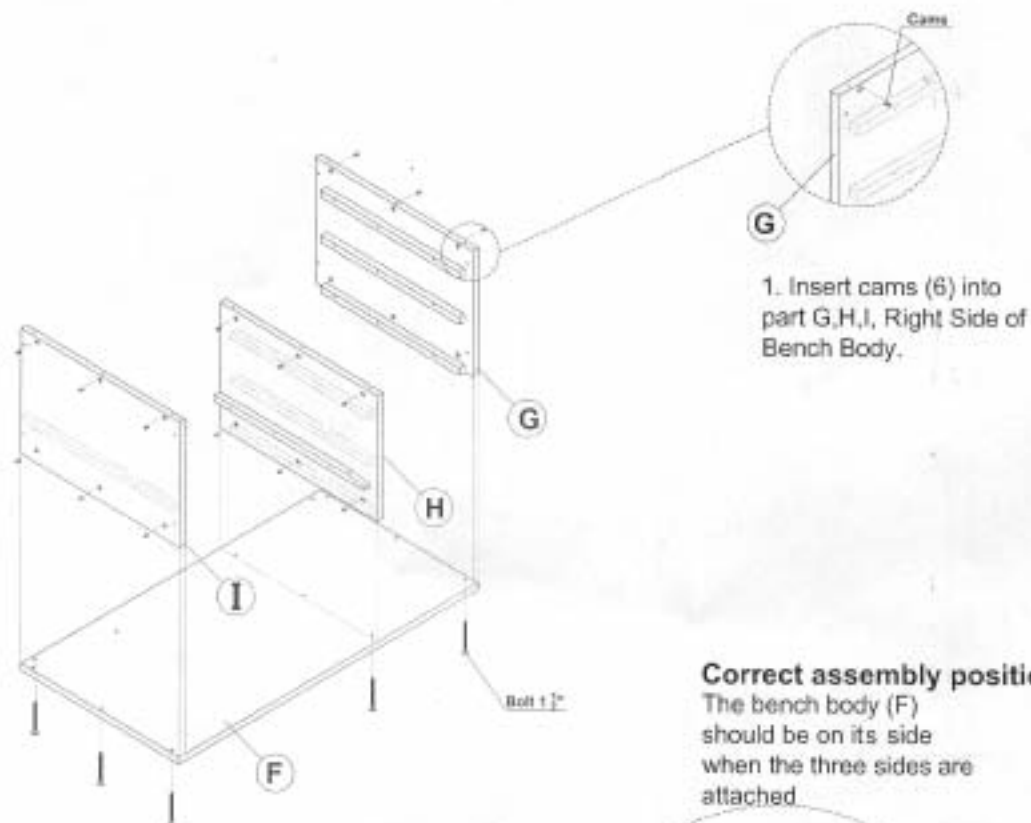

1. Insert cams (6) into part G,H,I, Right Side of Bench Body.

Correct assembly position

The bench body (F) should be on its side when the three sides are attached.

Attach parts G, H and I, right side, to part F, bench body bottom, using three $1\frac{1}{2}$ " bolts. Bolts are inserted into recessed holes on part F.

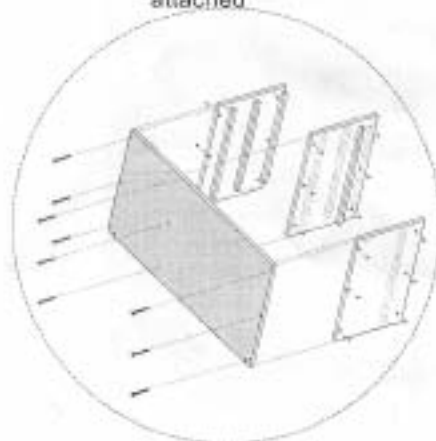

PARTS IDENTIFICATION

- F Bottom of bench body - (1)
- G Right side panel of bench body, 3 tracks on one side - (1)
- H Center panel of bench body, 3 tracks on one side, one track on other side - (1)
- I Left side of bench body, only on track- (1)

STAGE 2 - Bench Body

Assembly

Step 1

1. Insert cams (6) into part G,H,I, Right Side of Bench Body.
2. Stand part F, bottom of bench body, on its side.
3. Attach part G, right side, to part F, bench body bottom, using three $1\frac{1}{2}$ " bolts. Bolts are inserted into recessed holes on part F.
4. Insert cams (6) into part H, center panel of bench body.
5. Attach part H to part F using three $1\frac{1}{2}$ " bolts. The three tracks on part H must face the three tracks on part G.
6. Insert cams (6) into part I.
7. Attach part I to part F using three $1\frac{1}{2}$ " bolts. Track on part I must face inwards.

5

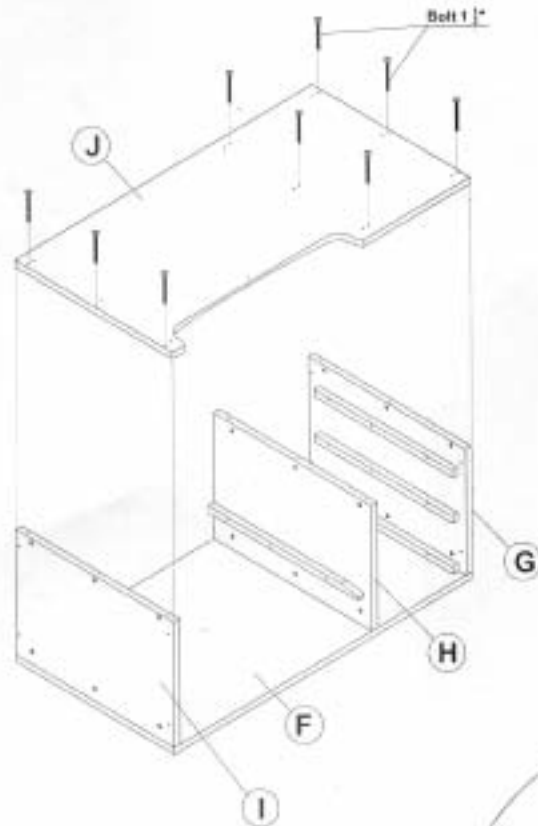

Final image of the Bench Body

PARTS IDENTIFICATION

- F Bottom of bench body - (1)
- G Right side panel of bench body, 3 tracks on one side - (1)
- H Center panel of bench body, 3 tracks on one side, one track on other side - (1)
- I Left side of bench body, only on track - (1)
- J Bench body top - (1)

STAGE 2 - Bench Body Assembly

Step 2

1. Carefully rotate bench to lay on the bottom bench body panel. See diagram.
2. Place Bench Body Top (J) on top of bench body with **recessed holes facing up**. Attach Bench Body Top (J) using nine 1½" bolts.

6

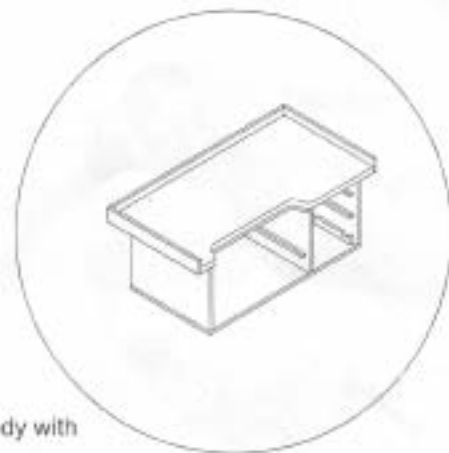
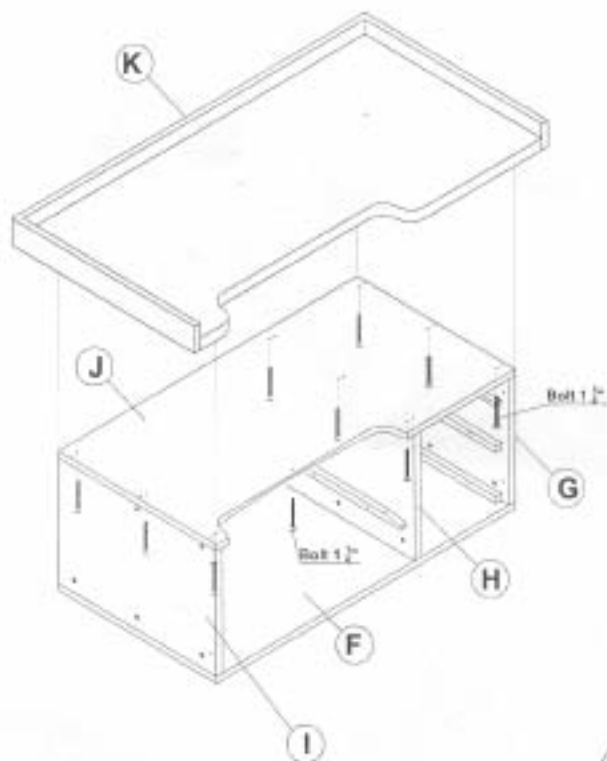

Final image of the Bench Body with the Bench Top attached

PARTS IDENTIFICATION

- F Bottom of bench body - (1)
- G Right side panel of bench body, 3 tracks on one side - (1)
- H Center panel of bench body, 3 tracks on one side, one track on other side - (1)
- I Left side of bench body, only one track - (1)
- J Bench body top - (1)
- K Bench top - (1)

STAGE 2 - Bench Body Assembly

Step 3

1. Position Bench Top (K) on bench body by lining up recessed portions of both.
2. Attach bench Top (K) to bench body using seven 1 $\frac{1}{4}$ " bolts.

7

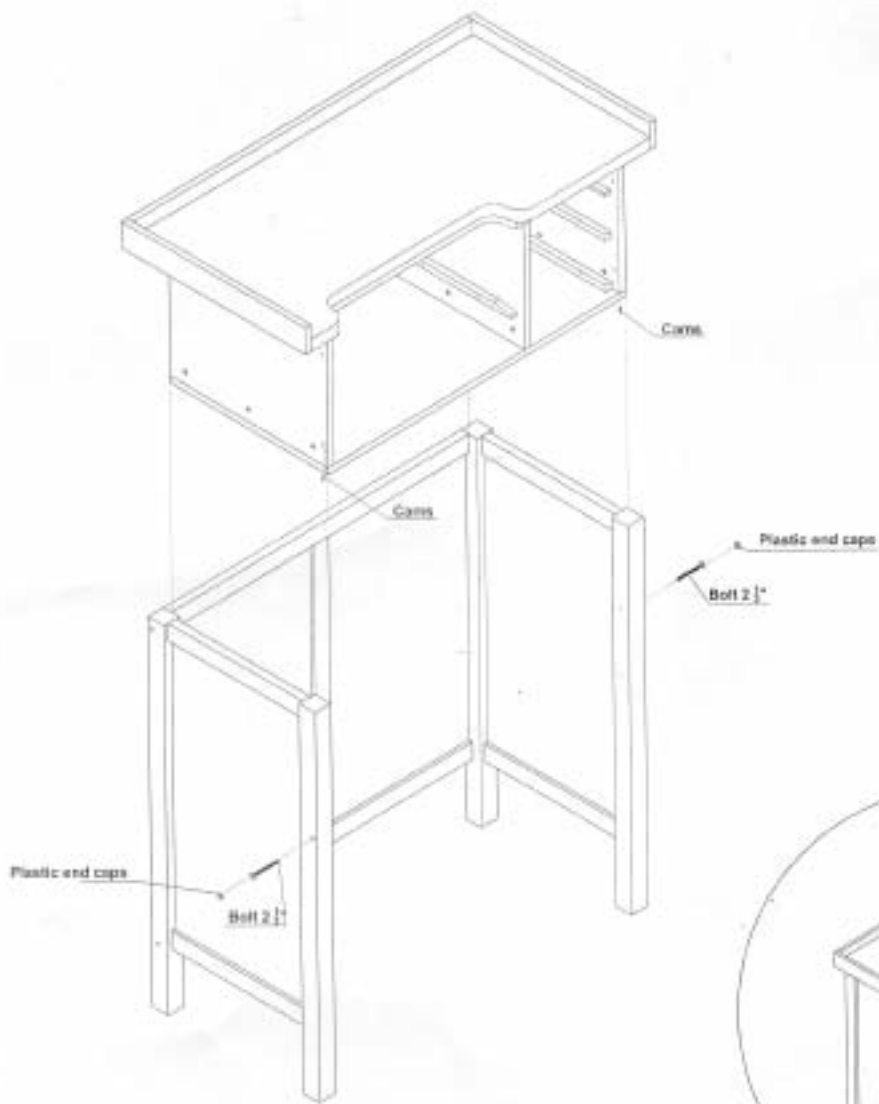

Final image of the Bench Body with the Bench Frame.

STAGE 3 - Attaching Bench Body to Bench Frame.

1. Fit bench body onto bench frame as shown.
2. Attach with eight $1\frac{1}{2}$ " bolts as shown.
3. Insert cams (2) into bottom of bench body.
4. Secure with $2\frac{1}{2}$ " bolts.
5. Place plastic end caps on side panels.

8

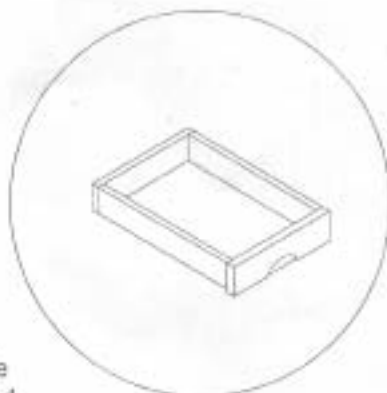
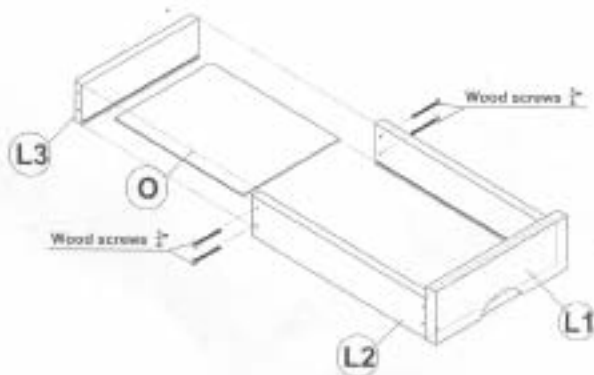
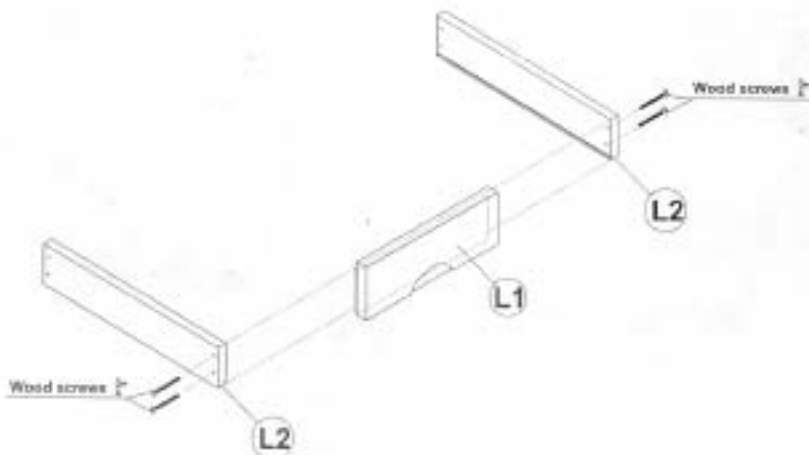

Final image of the drawer assembled

PARTS IDENTIFICATION

- L1 Large drawer front - (1)
- L2 Large drawer sides - (2)
- L3 Large drawer back - (1)
- M1 Medium drawer front - (1)
- M2 Medium drawer sides - (2)
- M3 Medium drawer back - (1)
- N1 Small drawer front - (1)
- N2 Small drawer sides - (2)
- N3 Small drawer back - (1)
- O Draw bottom - (3)

STAGE 4 - Drawer Assembly

1. Attach both large drawer sides (L2) to drawer front (L1) with $\frac{3}{4}$ " wood screws.
2. Insert drawer bottom (O) into grooves.
3. Attach large drawer back (L3) into assembled components using four $\frac{3}{4}$ " wood screws.
4. Repeat for Medium and Small Drawers. M1 - N3

9

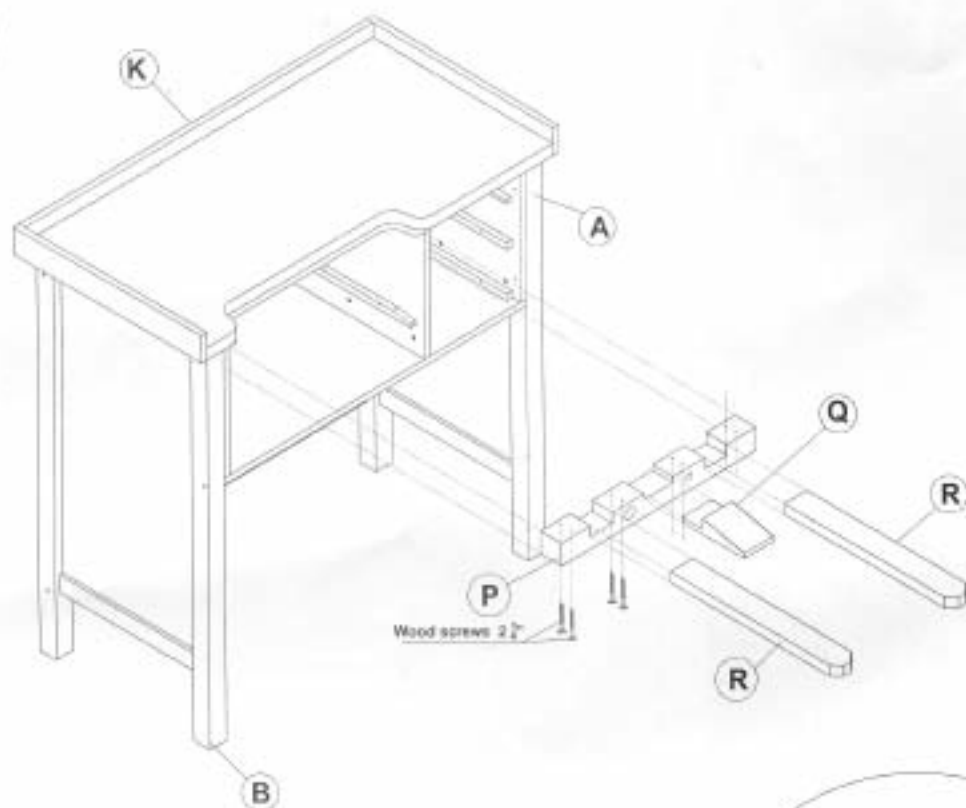

Final image of the
drawer assembled

PARTS IDENTIFICATION

- A Right Side - (1)
- B Left Side - (1)
- K Bench top - (1)
- P Bench pin holder - (1)
- Q Bench pin - (1)
- R Arm rest - (2)

STAGE 5 - Bench Pin Holder Attachment

1. Attach Bench Pin Holder (P) using eight 2 1/2" wood screws. See diagram.
2. Insert Bench pin (Q) and two arm rests (R).

10

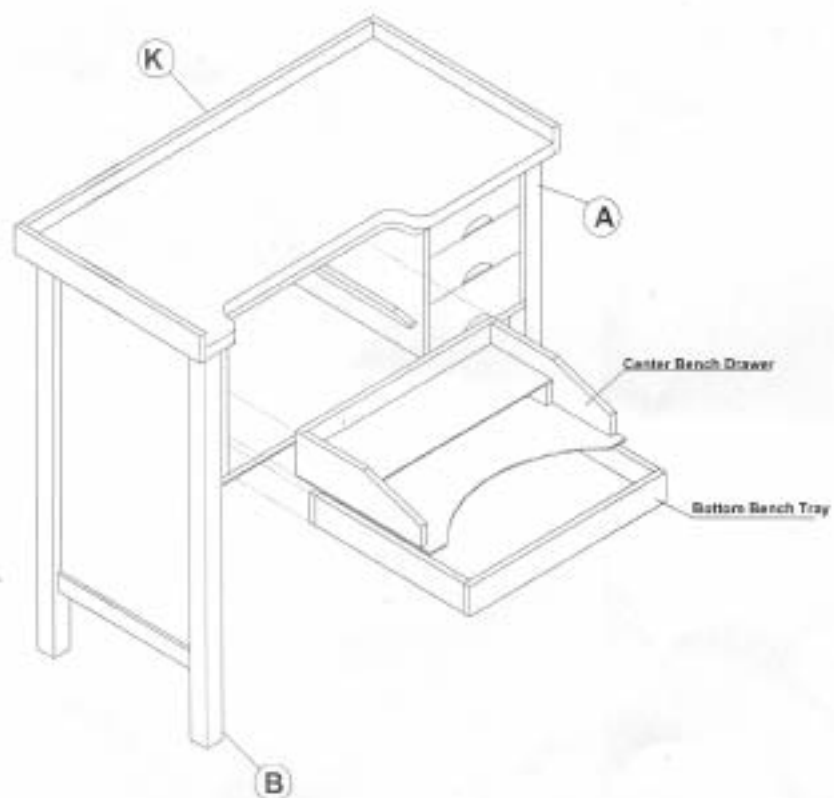

PARTS IDENTIFICATION

- A Right Side - (1)
- B Left Side - (1)
- K Bench top - (1)

STAGE 6

1. Insert the Center Bench Drawer above the Bottom Bench Tray into the larger desk compartment by placing them onto the drawer tracking.

11



FINAL IMAGE